

# CLASS 10000 MAG SERIES 96

RH ROTATION

*Moore*  
FANS

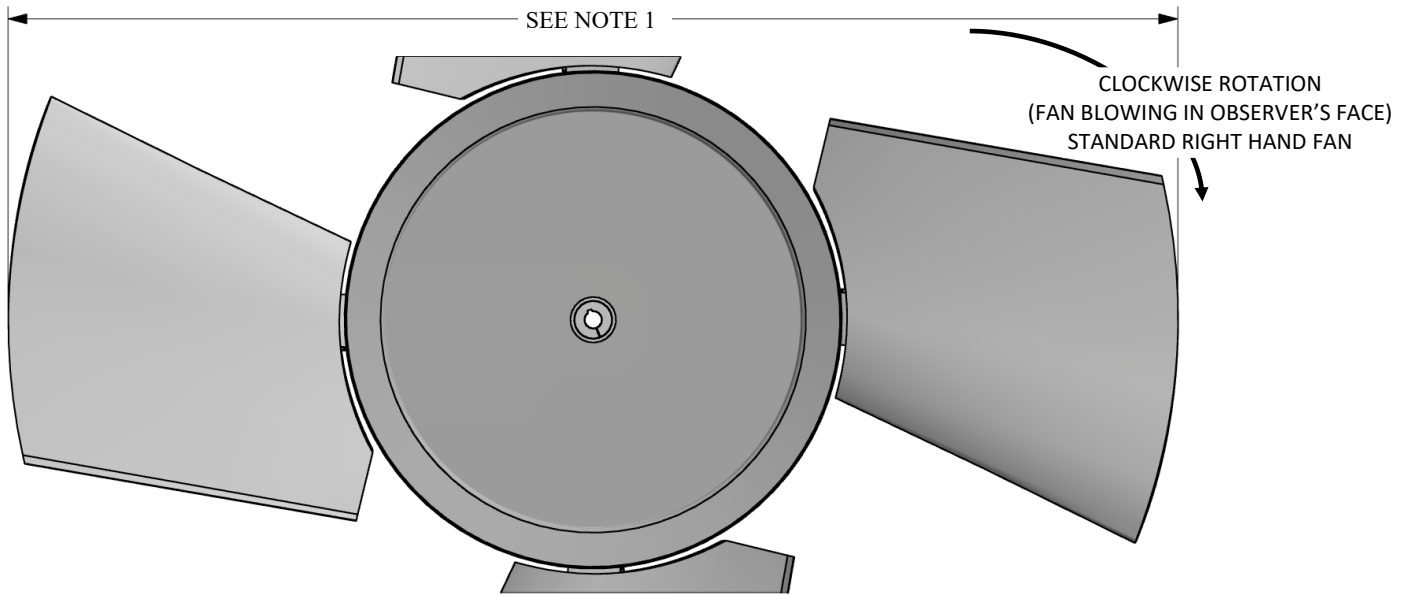
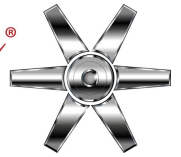

NOTE 1:  
MAXIMUM FAN DIAMETER EQUALS NOMINAL FAN DIAMETER.  
ADJUSTMENT OF ±1.5 INCHES POSSIBLE AT INSTALLATION

- A = BLADE TIP PROFILE HEIGHT (PATH WIDTH)
- B = BLADE RUNNING DROOP (C/L TO BOTTOM OF BLADE)
- C = MAXIMUM DROOP POSITION OF BLADES AT 30° (C/L TO BOTTOM OF BLADE)
- D = MINIMUM OBSTACLE CLEARANCE AT INLET
- F = CENTERLINE OF FAN TO BASE OF BUSHING (STANDARD HUB WITHOUT EXTENSION)
- G = BUSHING OVERALL HEIGHT
- H = MAXIMUM HEIGHT OF BLADE AT 30° (C/L TO AIR OUTLET SIDE)
- L = MAX . BUSHING TORQUE FT. LBS.
- # = WITH S.A.E. STANDARD SQUARE KEYWAY
- \* = WITH SHALLOW KEYWAY IN BUSHING
- o = MAX METRIC BORE WITH STANDARD KEYWAY

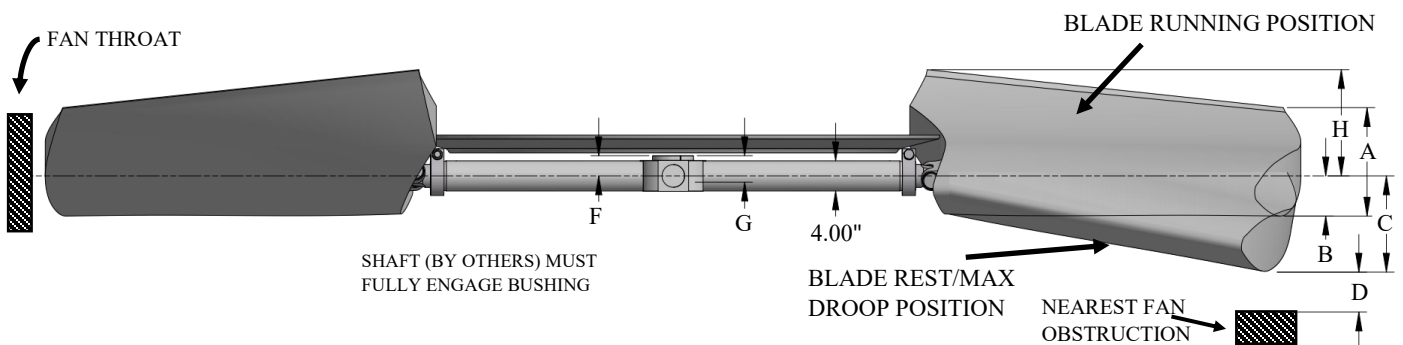

BUSHING AND/OR AIR SEAL  
CAN BE INSTALLED ON INLET  
OR OUTLET SIDE OF FAN

WITH FAN OPERATING AT 10000 FT/MINUTE BLADE TIP SPEED																
DIA	BLADE ANGLE			PERCENT BLADE LOADING		C	D	H	MAX BLADES	BUSHING TYPE	MAX # BORE	MAX * BORE	MAX o BORE	F	G	L
	10°	20°	30°	100%	75%											
17'	14.2"	21.9"	29.7"	16.5"	14.9"	20.7"	6"	23.1"	8	W	3.75"	4.000"	100	2.725"	2.8"	7300